

# Comfort System™

## General Instructions for Residential and Light Commercial Barometric Bypass Dampers

### HOW THE BYPASS DAMPER WORKS

As the individual zone dampers close, the system static pressure will tend to rise. In order to maintain constant airflow through the HVAC system, a barometric bypass damper will be required to bypass some of the discharge air back into the return. These bypass dampers can be used on systems with static pressure ratings up to 0.75" W.C.

### INSTALLING THE BYPASS DAMPER

The bypass damper should be installed in such a way as to connect the supply air duct to the return air duct. The damper should be installed in the horizontal position. Tap into the return air duct at least two feet back from the return air plenum if possible.

### ADJUSTING THE BYPASS DAMPER

With the HVAC unit running, adjust the weight located on the rod so that the bypass damper is fully closed when all zone dampers are in the full open position. To increase the system static pressure move the weight outward toward the end of the rod. To decrease the system pressure move the weight inward toward the damper shaft. To insure that all zone dampers are in the open position while adjusting the bypass damper, disconnect one of the two wires to each of the spring return open damper motors. Additional weights can be added to bypass damper arm if necessary.

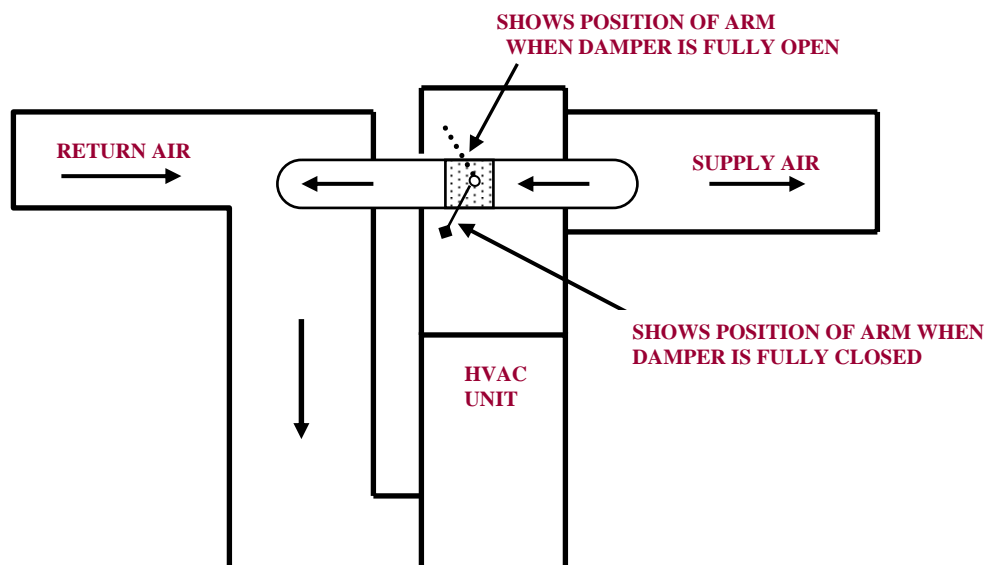

### BYPASS DAMPER SIZING BASED ON COOLING TONNAGE

2.5 TONS OR LESS USE 8"  
3 TONS USE 10"  
4 AND 5 TONS USE 12"  
7.5 TONS USE 14"

For systems larger than 7.5 tons, subtract the CFM of the smallest zone from the total system CFM, then size the bypass damper to handle 100% of this difference at 2,500 FPM

**Jackson**  
SYSTEMS

01-15-2005

5418 Elmwood Avenue Indianapolis, IN 46203-6025 317.788.6800 Fax: 317.227.1034

www.jacksonsystems.com

info@jacksonsystems.com