

Jackson SYSTEMS

Zone Control Made Simple™



DAMPER SPECIFICATIONS

CONSTRUCTION: 22 Ga. Galvanized Steel

LINKAGE: Direct Drive

SIZES: 5", 6", 7", 8", 9", 10", 12", 14", 16", 18"

MOTOR VOLTAGE: 24 Volts AC, 50/60 Hz, 6.5 Watts, 10VA

TORQUE: 35 in-oz to 55 in-oz

TEMPERATURE RATING: 0° F to 120° F Operating

HUMIDITY: 5% to 95% Non-Condensing

TIMING: 30 Sec. Powered, 8 Sec. Spring Return

CONNECTION: 4" Wire Leads (2)

STATIC PRESSURE: Maximum 1.0" W.C.

OPTION: 110 Volt Actuator

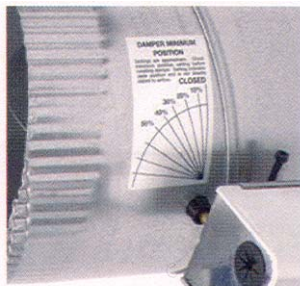

Minimum Position Adjustment

Comfort System™ "D" Series Round Zone Damper

The "D" series dampers are galvanized steel, single blade dampers complete with a 24 Volt, spring return actuator. These dampers are shipped complete and ready for installation. The "D" series damper can be installed in any position in any properly sized duct. They are rated for duct systems less than 1.0" W.C.

Dampers are available in 5", 6", 7", 8", 9", 10", 12", 14", 16", and 18" diameters. Dampers are ordered as D-xx, where xx is the 2-digit diameter.

"D" series dampers are typically shipped as normally open dampers that are powered closed and spring return open. A unique feature is that they can be easily field converted from powered closed to powered open.

The "D" series damper is powered by a 24 Volt AC, 50/60 Hz, spring return damper motor. The motor powers the damper closed and spring returns the damper open for fail-safe operation. Providing power to the motor drives the damper closed. Removing power from the motor allows it to spring back to the open position.

The 24 Volt, synchronous motor has been tested over 250,000 cycles to provide long life. To replace the motor, simply loosen the setscrew holding the motor to the damper.

The "D" series damper has a simple adjustment for setting the minimum position. Minimum position allows for bypass air. To set minimum position, loosen the setscrew, align the setscrew to the minimum position label and re-tighten.

Comfort™ SYSTEM

Jackson Systems, LLC

5418 Elmwood Avenue Indianapolis, IN 46203-6025

P: 317.788.6800 F: 317.227.1034 Toll Free: 888.652.9663

www.jacksonsystems.com

Jackson

SYSTEMS

Zone Control Made Simple™

DAMPER DIMENSIONS AND WEIGHTS

Diameter		Length		Weight	
Inches	MM	Inches	MM	Lbs.	Kg
5	127	10	254	3	1.36
6	152	10	254	3	1.36
7	179	10	254	4	1.82
8	203	10	254	4	1.82
9	238	10	254	4	1.82
10	254	10	254	5	2.27
12	305	10	254	6	2.72
14	356	10	254	7	3.18
16	406	10	254	8	3.63
18	457	10	254	8	3.63

DIMENSIONAL DRAWING

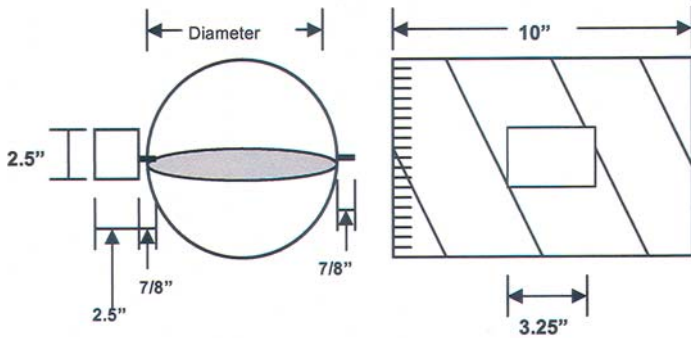

INSTALLATION

The "D" series damper is used in-line with the duct and can be installed on a take-off or at any point in the duct. It is recommended the damper be installed as close to the air handler as practical.

Place the un-crimped end of the damper over the crimped end of the take-off or rigid metal duct. Insert crimped end of the round damper into the un-crimped end of rigid round duct and secure with sheet metal screws. When using flexible duct, slip duct over end of the round damper and secure with duct straps (not provided).

The drawing to the right shows a top view of the damper in-line of the duct. It is recommended that the motor and blade shaft be parallel to the ground.

CONVERTING TO POWERED OPEN, NORMALLY CLOSED

All "D" series dampers are shipped as normally open, power closed dampers. The "D" series can be field converted by the following procedure:

1. Confirm the damper is in the normally open position (no power applied)
2. Loosen the 1/8" hex setscrew and remove motor from the blade shaft
3. Remove minimum position adjustment
4. Remove the plastic hole plug on opposite side of damper
5. Switch holes for the grommet and plug
6. Move the damper blade to the CLOSED position, making sure the blade is tight against the blade seal
7. Place the motor on opposite side of the damper blade shaft and place the anti-rotation shaft into the hole grommet
8. Tighten the hex screw (make sure the blade is still in the CLOSED position)
9. Wire the damper accordingly

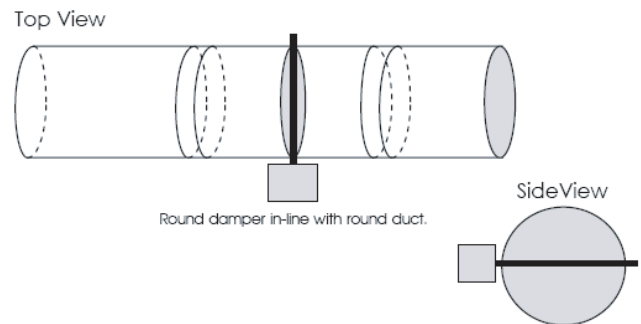

WIRING DIAGRAM

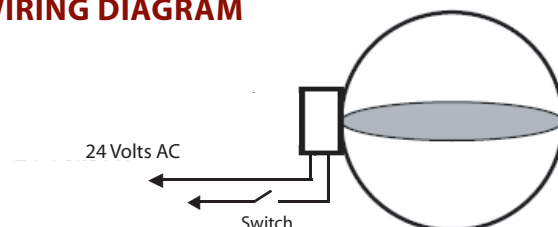

SPECIFICATION SHEET

D-XX Round, 2 Position, 2-wire, Motorized Zone Control Dampers

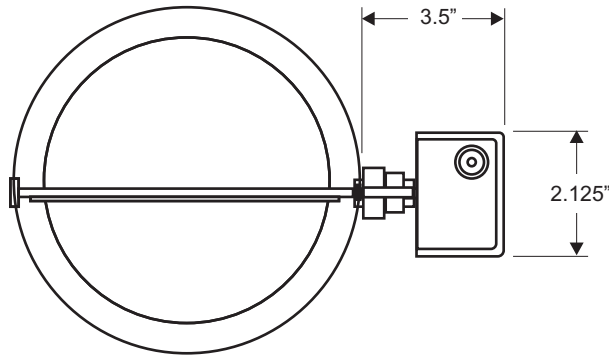

DAMPER SIZE	"A" DIMENSION
6"	10"
8"	10"
10"	10"
12"	13"
14"	14"
16"	14"
18"	14"
20"	14"

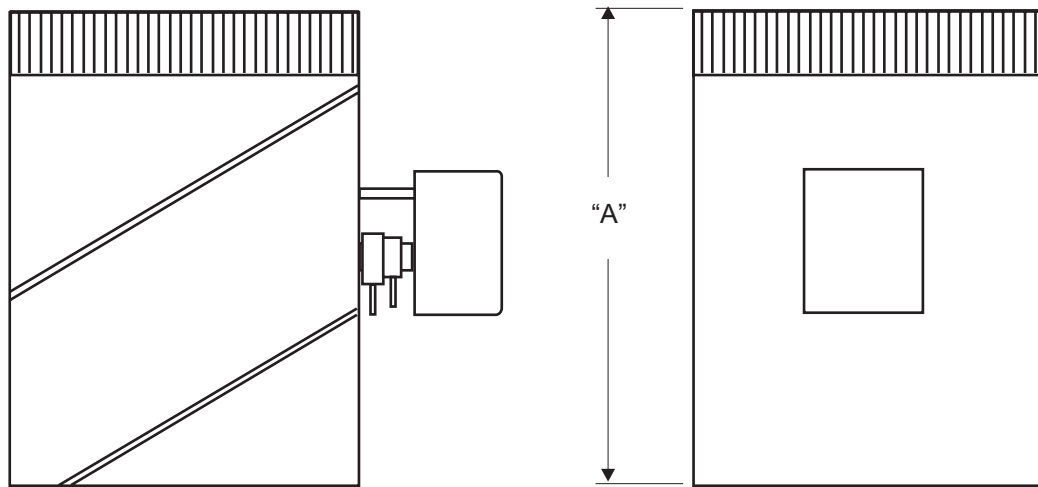

SPECIFICATIONS

DIMENSIONS:

Damper models HD-XX are available in standard sizes from 6" to 20"

APPLICATION:

Compatible for zone control and other HVAC applications with static pressures less than 1.0" w.c.

CONSTRUCTION:

- 18 gauge spiral steel shell
- 18 gauge steel blade
- 1/2" aluminum shaft
- Nylon bushings
- Air tight blade seals
- Minimum position adjustment

ELECTRICAL:

- 24 Volt, 10 VA, 0.356 Amp powered closed, spring return open actuator
- Also available in powered open, spring return closed
- Motor is impedance protected with no end switches

Drawings are intended to show general, overall product dimensions and provide guidance for installation clearance. Drawings are not to scale. Jackson Systems reserves the right to make product changes without notification or obligation.