

REVOLUTIONARY IAQ TECHNOLOGY

APCO-X is the result of more than a decade of development and is our most advanced indoor air treatment system. It combines UVC light and our proprietary activated carbon technology to safely & effectively neutralize odor-causing VOCs and biological contaminants. It not only treats the air but also helps keep the HVAC system clean and efficient and extend it's life.

FEATURES/BENEFITS

Exclusive V-Twin EverCarbon Matrix™ with nanotech antimicrobial coating	Features 65% more effective surface area, improving performance 33% over previous model
Advanced 3-year UVC 254nm quartz lamp	Long lasting, safe and effective
Four-way 360° installation	For up-flow, down-flow & horizontal installations
UL Validated to produce no harmful ozone	Scientifically tested ensuring safety
Continuously treats the whole-system	Treats the air in the entire home all the time and is virtually maintenance free (UVC lamp replacement only)
Translucent polycarbonate housing	Strong, lightweight and reliable
LED status and lamp fault indicator	To provide operational feedback



APCO-X DUAL is the best choice when there is not enough room over the coil. It includes a 2nd UVC light for coil disinfection.

FURNACE APPLICATION

SAFELY AND EFFECTIVELY TREAT THE OTHER 2/3RDS

Conventional filters are only effective against particulates, like dust. APCO-X is proven to safely reduce both biological and chemical contaminants inside the air system and throughout the building. Together, they address 99+% of the contaminants in the air.

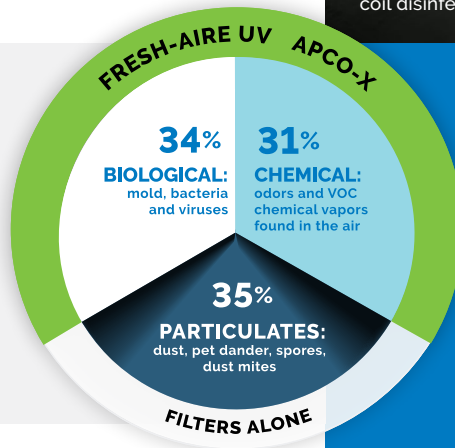

CLEANS THE COIL AND DRAIN PAN

Helps keep the HVAC system running efficiently and extend its life.

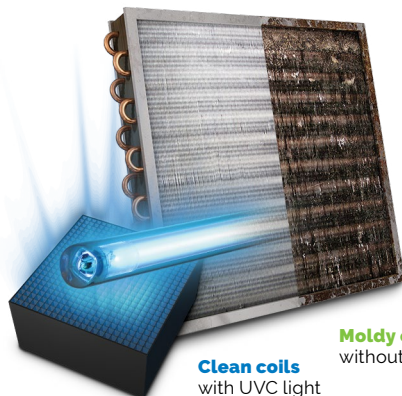

Clean coils with UVC light

Moldy coils without UVC light

CLEAN AIR



APCO-X Neutralizes Mold, Bacteria, Viruses, and Allergens

We are committed to developing and validating our products. APCO-X Testing achieved incredible results:

Fresh-Aire UV systems are not intended to diagnose, treat, prevent, or cure any disease.

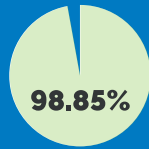

Bacteria (S.epideridis)*



Viruses (MS2 coliphage)*

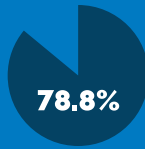

Mold (A.niger)*

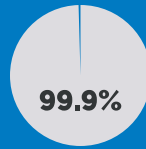

Odors (VOCs)*

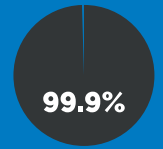

SARS-CoV-2 virus within 3 seconds of exposure**

* % Reduction of common indoor air contaminants over 4 hours. Tested at airflow velocity of 492-fpm (0.93m3/sec)

**The SARS-CoV-2 virus test was conducted at a distance of 6" on test surfaces in a laboratory setting.

SPECS

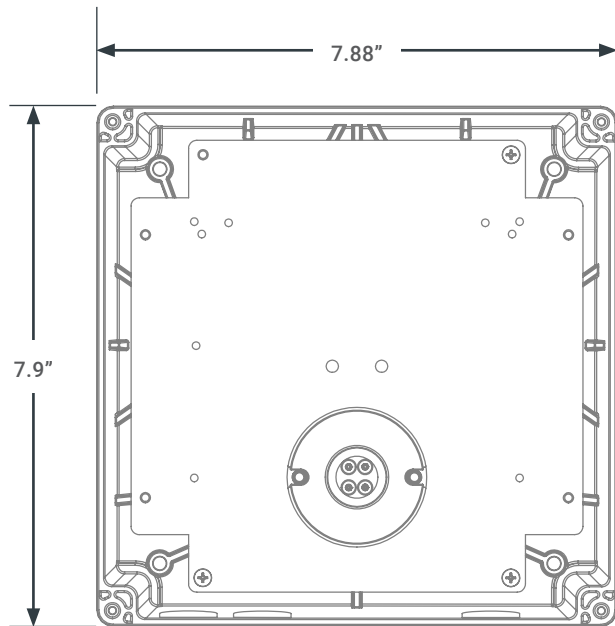

EPA
Est. Reg. No.
075179-FL-002

APCO-X Specs

UV Lamp	254 nm germicidal UV-C, quartz hot filament
Dimensions	Cell & Lamp: 5.8"W x 3.25"H x 13.2"D Enclosure: 7.6"L x 7.6"W x 2.2"D
ER models Electrical	18-32 VAC, 60 Hz, 0.68 Amps, 16 VA
SI DI models Electrical	110-277 VAC, 50/60 Hz, 0.51 Amps/120V Thru 0.22 Amps/277V
Pressure Drop	<0.01" w.c. @ 400 FPM
Warranty	Lifetime for all parts except lamp

Part Numbers

18-32 VAC	Replacement Lamp
TUV-APCOX-ER3	3 Year Lamp TUVL-315
18-32 VAC with 2nd UV Lamp for Coil	Replacement Lamp
TUV-APCOX-DER3	3 Year Lamp (2) TUVL-315
110-277 VAC	Replacement Lamp
TUV-APCOX-SI3-P	3 Year Lamp TUVL-315
110-277 VAC with 2nd UV Lamp for Coil	Replacement Lamp
TUV-APCOX-DI3-P	3 Year Lamp (2) TUVL-315

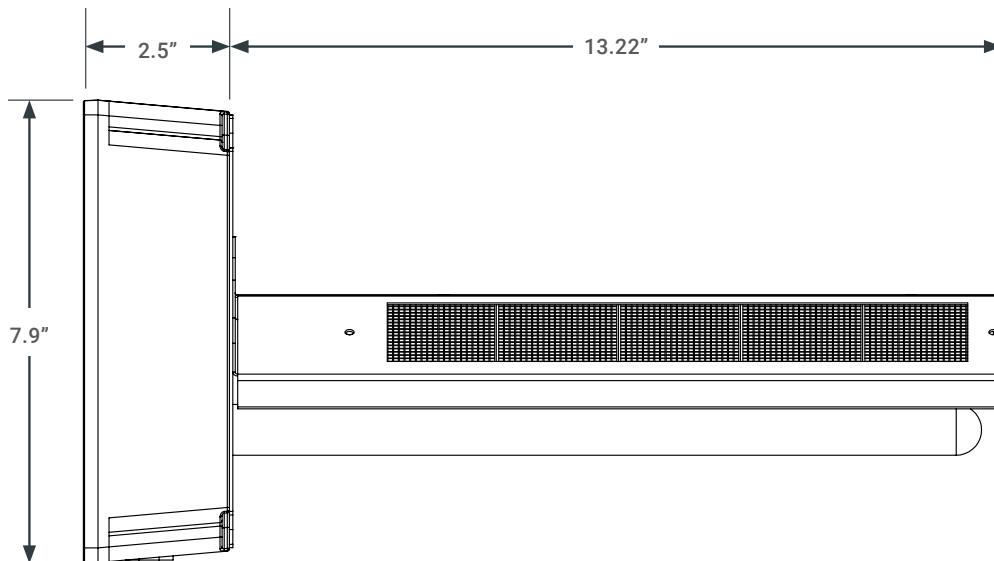

DESIGNED & ASSEMBLED IN THE U.S.A.