

SPECIFICATION SHEET

RD-XX 3-WIRE RETRO DAMPER™

Motorized Zone Control Dampers

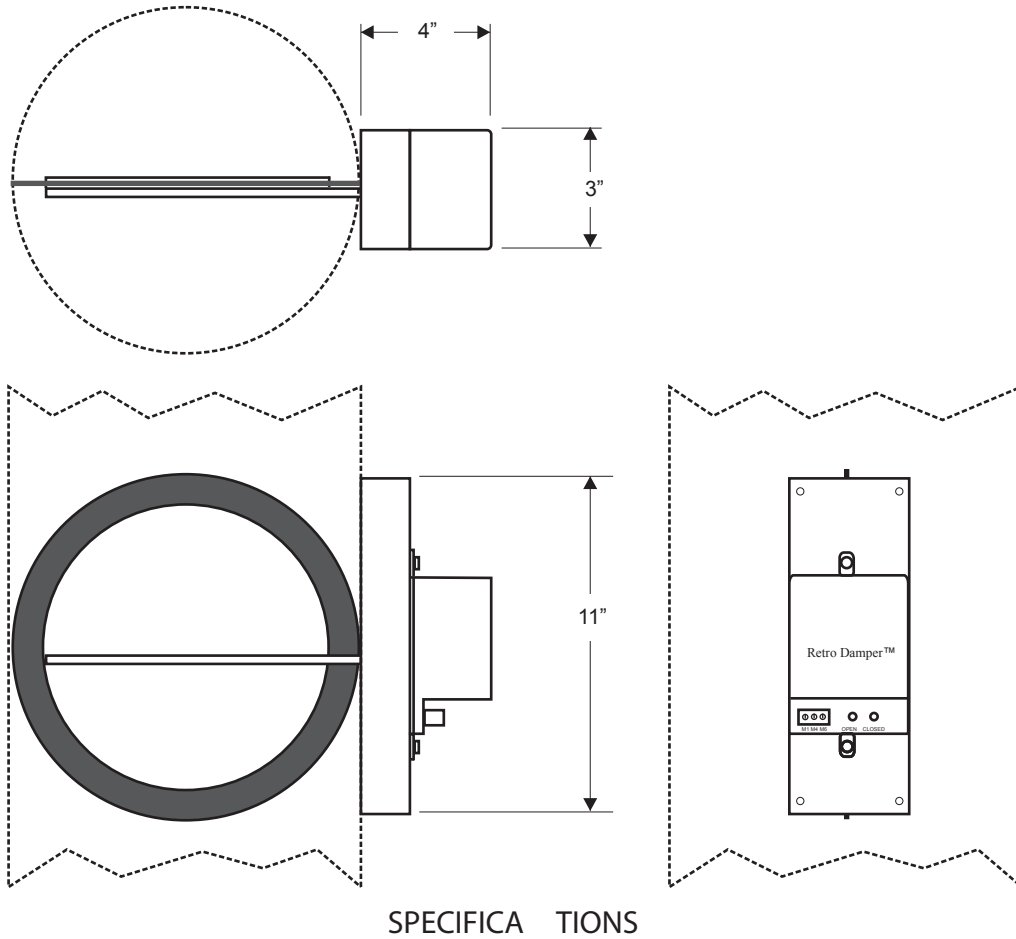

SPECIFICATIONS

DIMENSIONS:

Damper models RD-XX are available in standard sizes of 5", 6", 7", 8", 9" and 10"

APPLICATION:

Compatible for zone control and other HVAC applications with static pressures less than 1.0" WC

CONSTRUCTION:

- 18 gauge steel blade
- 3/8" solid aluminum shaft
- Air tight blade seals
- Minimum position adjustment

ELECTRICAL:

- 24 Volt, 3.8 VA
- 3-wire
- 34 lb.-in.torque
- 6 second timing

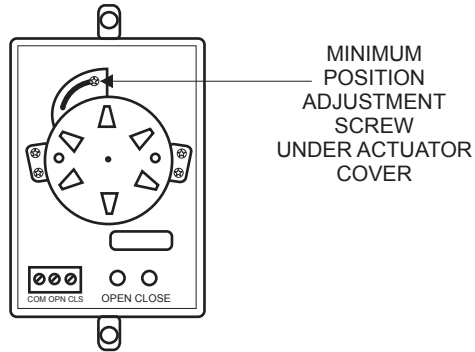

Drawings are intended to show general, overall product dimensions and provide guidance for installation clearance. Drawings are not to scale. Jackson Systems reserves the right to make product changes without notification or obligation.