



## PECO WAVE WIRELESS™ SYSTEM

TW SERIES THERMOSTATS AND RW SERIES CONTROL MODULE  
FOR PTAC/PTHP AND CERTAIN FAN COIL SYSTEMS



### HIGHLIGHTS

- Frequency Hopping Spread Spectrum Wireless
- 7 Day Programmable (TW206)
- ASHRAE 90.1, and Title 24 Compliant\*
- Occupancy HVAC Control Input
- Controlled Off Safety Option
- Key Pad Lockout - Partial or Full
- Setback Capability
- Auto/ Heat/ Cool/ Off
- Auto Summer/Winter Changeover Option
- Local or Remote Sensing
- LCD Display with Backlight
- Fahrenheit or Celsius Display

\*ASHRAE 90.1 or Title 24 compliance requires  
TW206 programmable thermostat + RW205 receiver module

### Reduce Installation, Increase Profits and Comfort

The PECO Wave Wireless System offers a cost-effective alternative to expensive or difficult rewiring retrofit projects. Unlike built-in controls, the wireless units can be removed and reinstalled as the building floorplan changes without rewiring walls.

The PECO Wave Wireless System reduces installation time, offering less disruption for occupants and decreased contractor labor time and expense.

### PECO Wave Wireless System Components

The TW205 wireless thermostat is a base level unit offering affordable basic features, such as 2 Heat/ 2 Cool, 3-speed fan, and manual or auto changeover.

The TW206 wireless thermostat, featuring Title 24 and ASHRAE 90.1 compliance, offers full 7 day, 4 event programmability making it ideal for condominiums, residential care facilities, or any PTAC, PTHP, or fan coil application where programmability is mandated by code. Additional energy saving features include range limit adjustment, staged fan, occupancy and setback control.

The RW205 receiver module receives input from the TW series thermostats as well as any occupancy sensing accessory installed to drive the functions of the PTAC, PTHP, and certain fan coil applications.

# T180 PROGRAMMABLE THERMOSTAT

## TECHNICAL SPECIFICATIONS

Temperature Range:	50° to 90°F (10° to 32°C)
Differential:	1°F (0.5°C)
Input Power:	TW205 / TW206 thermostat: Two AA alkaline batteries or 24 VAC, 50/60 Hz RW205 receiver: 24 VAC or 100-277 VAC, 50/60 Hz
Wireless Type:	902 to 928 MHz Band, FHSS (Frequency Hopping Spread Spectrum)
Wireless Range:	100 ft minimum in open air
Operating Temperature:	0° to 120°F (-17° to 48°C)
Shipping Temperature:	-20° to 130°F (-28° to 54°C)
Operating Humidity:	5% to 95% RH, non-condensing
Physical Dimensions:	TW205 / TW206: 4.6"H x 6"W x 1.2"D RW205: 5"H x 4"W x 1.3"D



## WIRING DIAGRAM - RW205

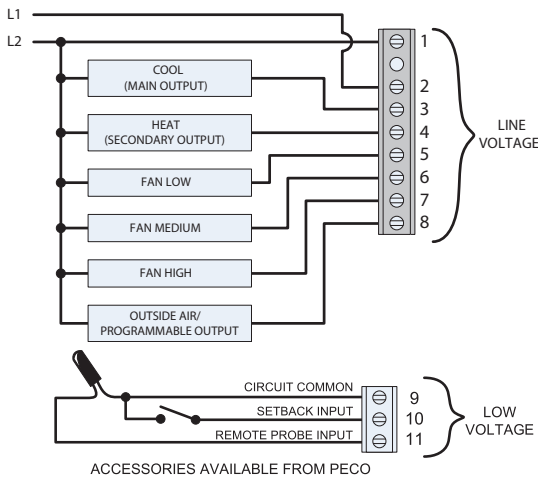

## MOUNTING INSTRUCTIONS

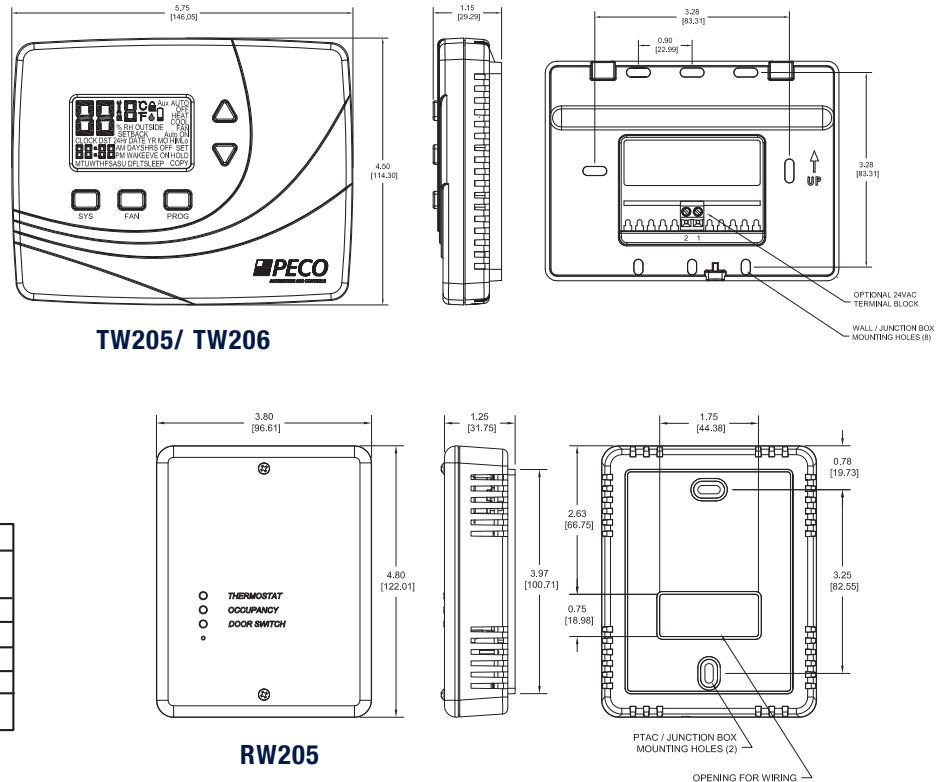

## RATINGS

VOLTAGE	RATINGS		RES AMPS	PILOT DUTY	HP
	FLA	LRA			
24 VAC	NA	NA	NA	24 VA	NA
120 VAC	5.8	34.8	6.0	125 VA	1/4
240 VAC	2.9	17.4	5.0	125 VA	1/4
277 VAC	2.4	14.4	4.2	125 VA	1/4

COMBINED LOAD CURRENT NOT TO EXCEED 20 AMPS

## MODEL SELECTION GUIDE

Model	Part Number	Description
TW205-001	69402	PECO Wave Wireless System, non-programmable thermostat, 2 Heat/ 2 Cool, 24V or battery powered
TW206-001	69556	PECO Wave Wireless System, 7 day, 4 event programmable thermostat, 2 Heat/ 2 Cool, 24V or battery powered
RW205-001	69403	PECO Wave Wireless System, receiver module



**Automation and Controls**  
Division of PECO, Inc.  
PO Box 82189, Portland, OR 97282

Phone: 800-874-8547 / 503-233-6401  
Email: sales@pecomanufacturing.com  
www.pecomanufacturing.com