

Instruction Sheet

007e⁻² ECM High-Efficiency Circulator

SUPERSEDES: January 14, 2021

EFFECTIVE: August 16, 2021

Plant ID No. 001-5000

DESCRIPTION:

The 007e-2 is a variable speed, high-efficiency wet rotor circulator with an ECM, permanent magnet motor. Its ECM performance is equivalent to the legendary Taco 007 and ideal for hydronic systems zoned with circulators or zone valves. It reduces power consumption by up to 85% compared to equivalent AC permanent split capacitor circulators.

APPLICATION:

- Maximum operating pressure: 125 psi (8.6 bar)
- Maximum water temperature: 230°F (110°C)
- Electrical specifications:
 - Voltage: 110-120V, 50/60 Hz, single phase
 - Maximum operating power: 44W
 - Maximum amp rating: 0.54
- Equipped with a cast iron casing and should be used for closed loop systems only
- Not suitable for open loop potable water or chilled water systems
- Taco circulator pumps are for indoor use only – employer uniquement à l'intérieur
- Acceptable for use with water or maximum of 50% water/glycol solution
- Not recommended for systems designed for constant circulation

FEATURES:

- ECM performance equivalent to the legendary Taco 007 circulator
- Multi-color LED display showing power on and error code diagnostics
- Use with a Taco Zone Valve Control (ZVC) or Switching Relay (SR) for ON/OFF operation
- Nut capture feature on flanges for easier fit up
- Dual electrical knockouts and 6" stranded wire leads for easy wiring
- Double insulated - no ground-wire required
- Whisper quiet operation
- BIO Barrier® protects the pump from system contaminants
- SureStart® - automatic unblocking and air purging mode
- Optional 2-way universal flange model for easy fit-up to any flange orientation
- Integral Flow Check (IFC®) included - Field installed
- Green Mode active system monitoring and power optimization

Figure 1:

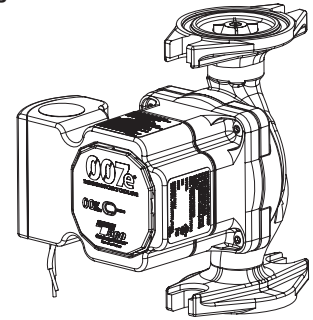

Standard flange model: 007e-2F2

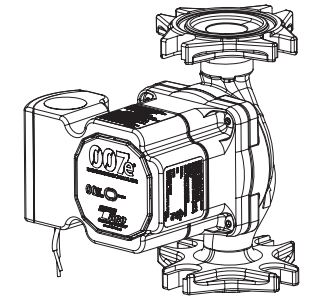

Optional 2-way flange model: 007e-2F4



WARNING: Do not use in swimming pool or spa areas. Pump has not been investigated for these applications.

AVERTISSEMENT: Ne pas utiliser dans une piscine ou un spa. La pompe n'a pas été étudiée pour ces applications.

CAUTION: The addition of petroleum based fluids or certain chemical additives to systems using TACO equipment voids the warranty. Consult factory for fluid compatibility.

ATTENTION: L'ajout de liquides à base de pétrole ou de certains additifs chimiques à des systèmes utilisant un équipement TACO annule la garantie. Consultez le fabricant pour connaître la compatibilité de liquides.

CAUTION: Installations at elevations over 5000 feet must have higher fill pressure of 20 psi minimum to prevent pump cavitation and flashing. Premature failure may result. Adjust expansion tank pressure to equal fill pressure. A larger size expansion tank may be required.

ATTENTION: Des installations à des altitudes de plus de 1600 mètres doivent présenter une pression de remplissage plus élevée de 20 psi au minimum afin d'éviter toute cavitation ou flashing de la pompe. Une défaillance prématurée peut en résulter. Réglez la pression du réservoir d'expansion de façon qu'elle soit égale à la pression de remplissage. Un réservoir d'expansion d'une taille supérieure peut être nécessaire.

Figure 2:

PREFERRED PIPING FOR CIRCULATORS ON BOILER SUPPLY

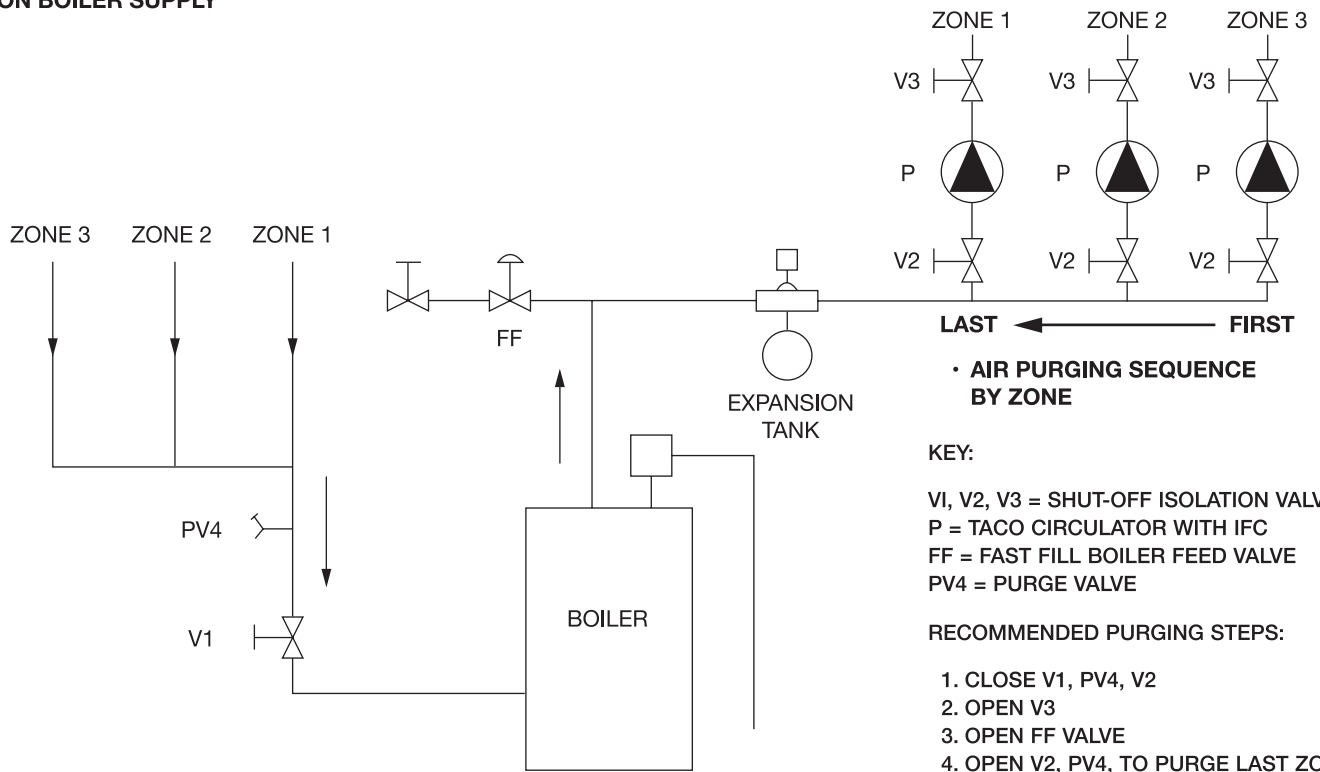

• AIR PURGING SEQUENCE BY ZONE

KEY:

- V1, V2, V3 = SHUT-OFF ISOLATION VALVE
- P = TACO CIRCULATOR WITH IFC
- FF = FAST FILL BOILER FEED VALVE
- PV4 = PURGE VALVE

RECOMMENDED PURGING STEPS:

1. CLOSE V1, PV4, V2
2. OPEN V3
3. OPEN FF VALVE
4. OPEN V2, PV4, TO PURGE LAST ZONE FIRST (ZONE 3)
5. CLOSE FF VALVE
6. CLOSE V2, PV4
7. REPEAT STEPS 1 TO 6 FOR EACH ADDITIONAL ZONE, PURGE ZONE 1 LAST
8. OPEN V1 WHEN ALL ZONES ARE PURGED
9. ADJUST SYSTEM TO DESIRED OPERATING FILL PRESSURE IF REQUIRED

ALTERNATE PIPING FOR CIRCULATORS ON BOILER RETURN

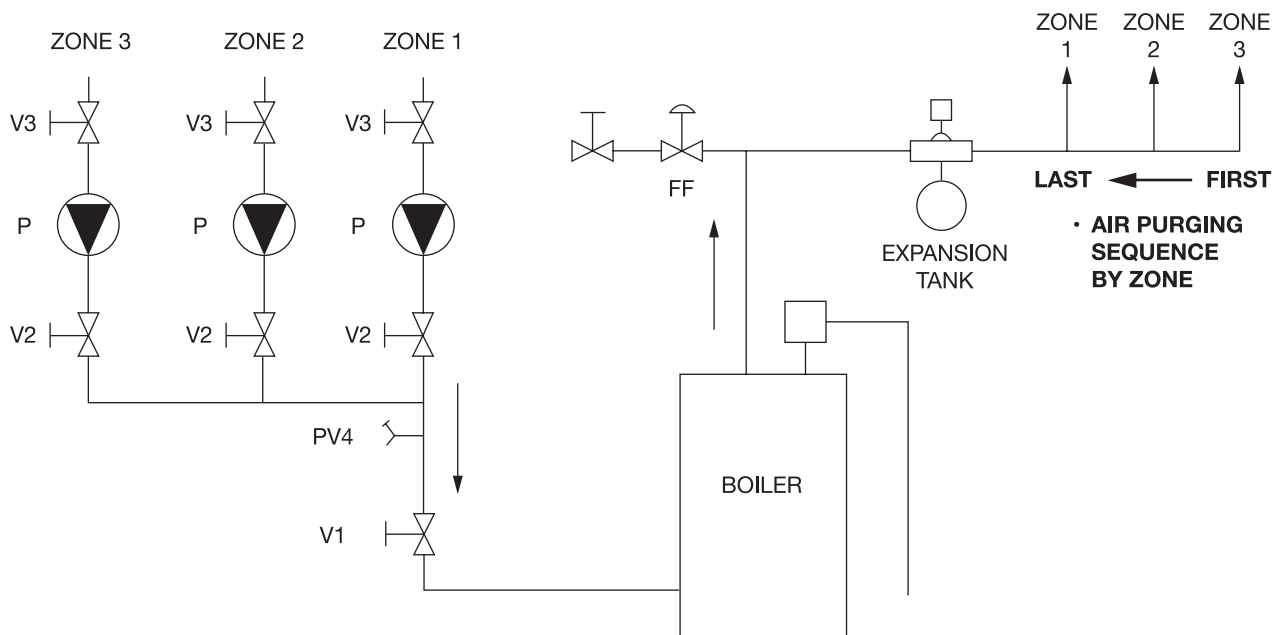

• AIR PURGING SEQUENCE BY ZONE

Figure 3:

PREFERRED PIPING FOR ZONE VALVES ON BOILER SUPPLY

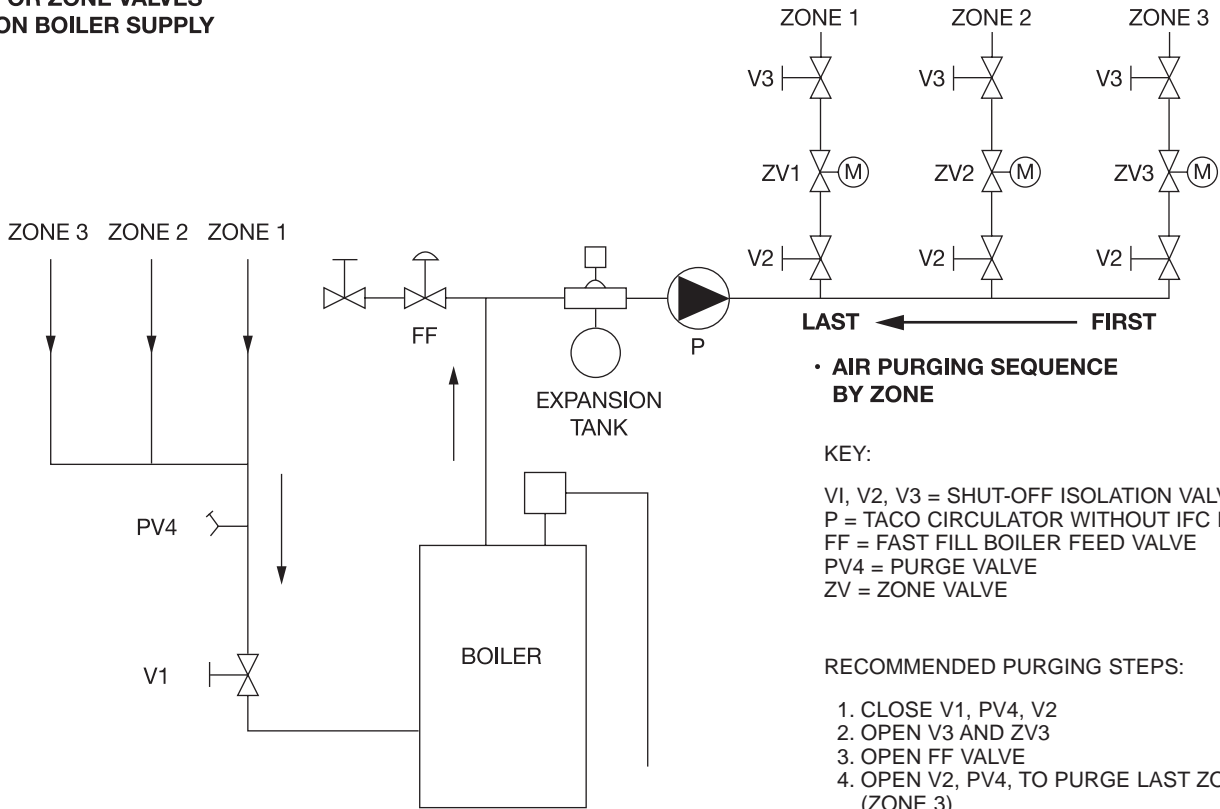

- RECOMMENDED PURGING STEPS:**
1. CLOSE V1, PV4, V2
 2. OPEN V3 AND ZV3
 3. OPEN FF VALVE
 4. OPEN V2, PV4, TO PURGE LAST ZONE FIRST (ZONE 3)
 5. CLOSE FF VALVE
 6. CLOSE V2, PV4
 7. REPEAT STEPS 1 TO 6 FOR EACH ADDITIONAL ZONE, PURGE ZONE 1 LAST
 8. OPEN V1 WHEN ALL ZONES ARE PURGED
 9. ADJUST SYSTEM TO DESIRED OPERATING FILL PRESSURE IF REQUIRED
 10. MOVE ALL ZV TO CLOSED/AUTOMATIC POSITION

ALTERNATE PIPING FOR ZONE VALVES ON BOILER RETURN

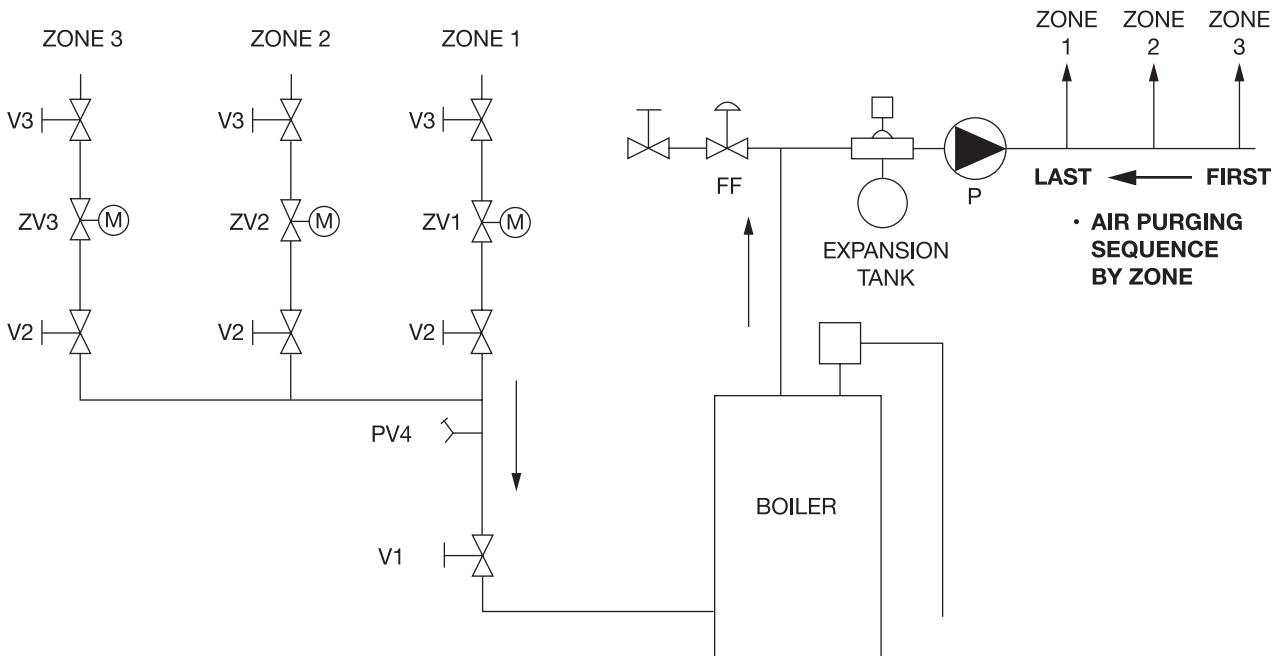

- Location:** The circulator can be installed on the supply or return side of the boiler but for best system performance, it should always pump away from the expansion tank. See piping diagrams in Figure 2 and Figure 3.

CAUTION: Do not use flat rubber gaskets. Only use O-ring gaskets provided or leaks may result. Warranty will be void.

- Mounting position:** Circulator must be mounted with the motor in the horizontal position. See diagrams below for acceptable motor mounting orientations.

ACCEPTABLE MOTOR MOUNTING POSITIONS AND EZ CASING ROTATION

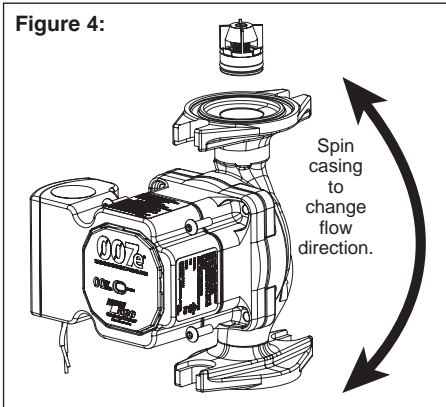

Always install with motor in horizontal orientation. Position electrical junction box at 9 o'clock for best viewing orientation. Pump casing may be rotated to change flow direction. Locate the arrow on the casing body to determine flow direction.

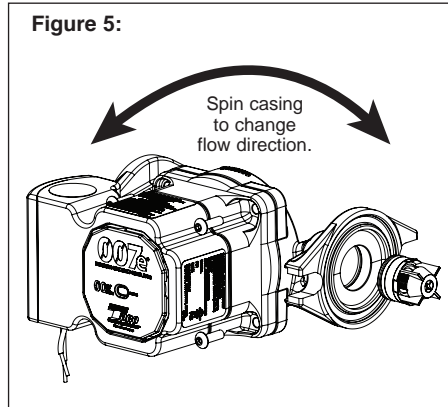

To rotate the pump casing, remove the 4 motor screws. **When rotating pump casing position, DO NOT detach motor housing from the casing.** Damage to the casing O-ring and leakage may result. Simply spin casing to the proper flow direction desired as shown in Figure 4 and Figure 5. Reattach the 4 screws (1/8" allen wrench required). Be sure motor is positioned correctly and is seated evenly to prevent leakage or damage to O-ring. Tighten motor screws evenly to **25-38** in-lbs torque.

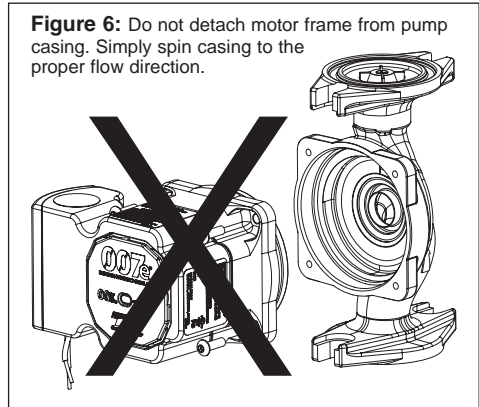

CAUTION: When rotating pump body position, do not detach motor housing from the casing. Damage to the casing O-ring and leakage may result.

Integral Flow Check (IFC®) option - An IFC® is included in carton. If required, press IFC into machined discharge port with plunger and o-ring facing in, until it snaps into place. Before installing, press IFC plunger to be sure it moves freely. See Figures: 4 & 5 above.

CAUTION: To reduce the possibility of noise transmission, be sure to add vibration dampeners to piping when mounting circulator to wall or floor joists.

ATTENTION: Pour réduire la possibilité de transmission de bruit, veuillez à ajouter des amortisseurs de vibration à la tuyauterie lors du montage du circulateur sur des chevêtres de mur ou de plancher.

- Filling the system:** Fill the system with tap water or a maximum of 50% propylene-glycol and water solution. The system must be filled before operating the circulator. The bearings are water lubricated and should not be allowed to operate dry. Filling the system will result in immediate lubrication of the bearings. It is always good practice to flush a new system of foreign matter before starting the circulator.

WARNING: Risk of electric shock. To reduce the risk of electric shock, be certain that it is connected only to a properly grounded, grounding-type receptacle. Follow all local electrical and plumbing codes.

AVERTISSEMENT: Risque de choc électrique. Pour réduire le risque de choc électrique, veuillez à ce qu'elle soit raccordée uniquement à un réceptacle de type mise à la terre proprement mis à la terre. Respectez tous les codes de plomberie et électriques locaux.

WARNING: Use supply wires suitable for 90°C. AVERTISSEMENT: Employer des fils d'alimentation adéquats pour 90°C.

WARNING: Disconnect power when servicing. AVERTISSEMENT : Couper l'alimentation lors de l'entretien.

CAUTION: Use flexible conduit only. Not for use with rigid conduit. ATTENTION : N'utiliser que du conduit flexible ; n'est pas fait pour du conduit rigide.

WARNING: SERVICING OF DOUBLE-INSULATED APPLIANCES. A double-insulated appliance is marked with one or more of the following: The words "DOUBLE INSULATION" or "DOUBLE INSULATED" or the double insulation symbol (square within a square). In a double-insulated appliance, two systems of insulation are provided instead of grounding. No grounding means is provided on a double-insulated appliance, nor should a means for grounding be added. Servicing a double-insulated appliance requires extreme care and knowledge of the system, and should be done by qualified service personnel. Replacement parts for a double-insulated appliance must be identical to the parts they replace.

AVERTISSEMENT : ENTRETIEN DES APPAREILS À DOUBLE ISOLATION. Un appareil à double isolation est marqué avec un ou plusieurs des éléments suivants : les mots « DOUBLE INSULATION » ou « DOUBLE INSULATED » ou le symbole de double isolation (carré dans un carré). Dans un appareil à double isolation, deux systèmes d'isolation sont fournis plutôt que la mise à la terre ; aucun moyen de mise à la terre n'est fourni ni ne doit être ajouté. L'entretien d'un appareil à double isolation exige de grandes précautions et une connaissance approfondie du système, et doit être effectué par un technicien qualifié. Les pièces de rechange pour un appareil à double isolation doivent être identiques aux pièces remplacées.

4. **Wiring the circulator:** Disconnect the AC power supply. Remove the terminal box cover. Attach a wiring connector into the knockout hole. Use a flexible conduit only. Connect Line/Hot power to the black lead, neutral to the white lead. See wiring diagram to the right. Replace the terminal box cover.

Note: If pigtail leads provided are not used, be sure to trim field wire to a strip length of .25" (+/- .025") to prevent exposed wire causing a short at the terminal plug. Connect line and neutral to green terminal plug as shown in the Wiring Diagram. Depress the spring tab with a small screwdriver to insert wire into the plug. Release tabs to complete connection. The 007e-2 is a double insulated circulator. No grounding wire is necessary.

5. **Start the circulator:** When purging the system, it is recommended to run the circulator long enough to remove all remaining air from the bearing chamber. This is especially important when installing the circulator in the off-season. An orange LED will illuminate when the 007e-2 is powered on.
6. **Green Mode:** Responsive technology actively monitors system conditions and automatically adjusts to optimize power consumption. In this mode the LED changes to green.

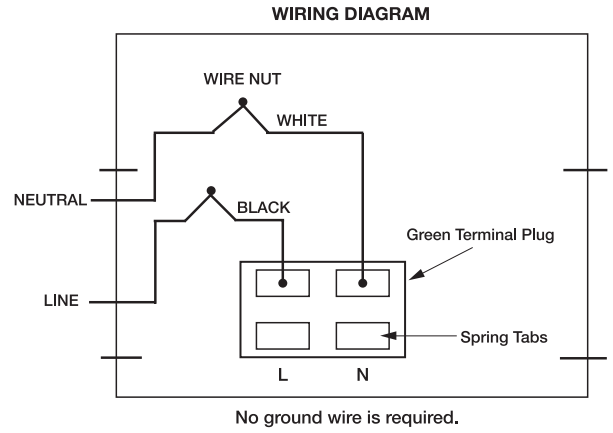

CAUTION: Never run the circulator dry or permanent damage may result.
ATTENTION: Ne laissez jamais le circulateur tourner à sec, des dommages permanents peuvent en résulter.

007e-2 Performance Curves

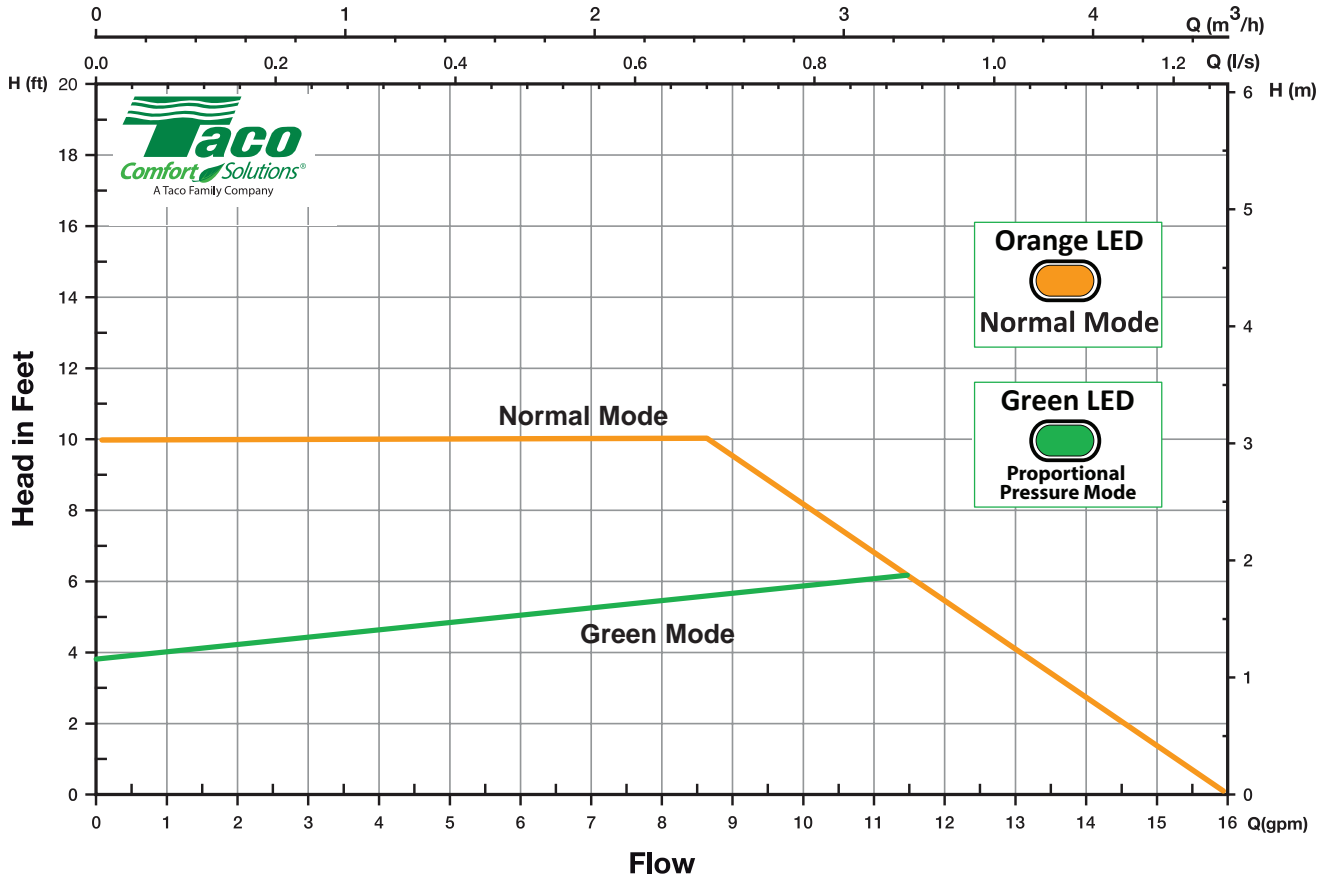

Green Mode: After 7 days of constant circulation, the 007e will self-adjust to Green Mode curve (low proportional pressure) for power optimization. See Green mode curve above. When the 007e-2 cycles OFF, the circulator resets to original Normal Mode curve.

CAUTION: Do not attempt to remove LED panel from circulator. Serious damage to circulator electronics may result.
ATTENTION: N'essayez pas de retirer le panneau de LED du circulateur. Des dommages sérieux à l'électronique du circulateur peuvent en résulter.

7. Troubleshooting the error codes: Listed below are potential diagnostic error codes which will appear on the LED display in case of a malfunction.

FAULTS	CONTROL PANEL	CAUSES	REMEDIES
The circulator is noisy	LED on	Suction pressure is insufficient - cavitation	Increase the system suction pressure within the permissible range.
	LED on	Presence of foreign bodies in the impeller	Disassemble the motor and clean the impeller.
Loud noises of water circulation	Flashing white LED	Air in the system. Pump may be air-bound.	Vent the system. Repeat fill and purge steps.
Circulator is not running although the electrical power supply is switched on	LED off	Lack of power supply	Verify voltage value of the electric plant. Verify the connection of the motor.
		Circuit breaker might be tripped	Check circuit breaker at panel and reset if necessary
		The circulator is defective	Replace the pump.
		Overheating	Let the pump cool down for some minutes. Then try to re-start it. Verify that the water and ambient temperature are within the indicated temperature ranges.
	LED red	The rotor is blocked	Disassemble the motor and clean the impeller. See unlocking procedure below.
		Insufficient supply voltage	Verify that the power supply matches the data on the name plate.
Building does not get warm.	LED on	System may be air-bound	Vent system. Repeat fill and purge steps.

8. Unlocking Procedure: A red light in the LED indicates the circulator is locked or sticking. Disconnect and connect power supply to start the automatic release process. The circulator makes 100 attempts to restart (process lasts approximately 15 minutes). Every restart is signalled by a short white flash of LED light. If the locking is not removed through the automatic release process after 100 attempts to restart the circulator, it goes into standby and the LED remains red. In this case follow the manual procedure described in the next steps: during any attempt, the red LED light keeps blinking; after that the circulator tries again to start. If the locking is not removed through the automatic release process (the warning light returns to be red), perform the manual steps described below.

1. Disconnect power supply - the warning light switches off
2. Close both isolating valves and allow cooling. If there are no shut-off devices, drain the system so that the fluid level is beneath that of the circulator
3. Loosen 4 motor bolts. Remove motor from casing. Carefully pull the rotor/impeller from the motor
4. Remove impurities and deposits from the impeller and casing
5. Reinsert the rotor/impeller into the motor
6. Connect power supply. Check for impeller rotation
7. If the circulator still doesn't run it will need to be replaced

Replacement Parts

198-213 RP	Casing O-ring
198-214 RP	Wiring plug connector (green)
198-215 RP	Terminal box cover (black)
198-217 RP	Terminal box cover screws (5 per bag)
0010-025 RP	Integral Flow Check (IFC®)
007-007 RP	Flange gasket set

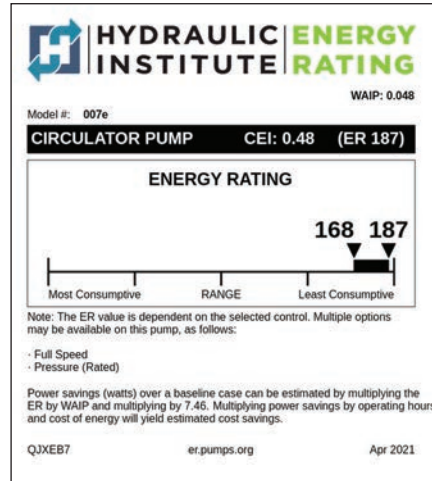

LIMITED WARRANTY STATEMENT

Taco, Inc. will repair or replace without charge (at the company's option) any Taco High-Efficiency circulator or circulator part which is proven defective under normal use within three (3) years from the date of manufacture.

In order to obtain service under this warranty, it is the responsibility of the purchaser to promptly notify the local Taco stocking distributor or Taco in writing and promptly deliver the subject product or part, delivery pre-paid, to the stocking distributor. For assistance on warranty returns, the purchaser may either contact the local Taco stocking distributor or Taco. If the subject product or part contains no defect as covered in this warranty, the purchaser will be billed for parts and labor charges in effect at time of factory examination and repair.

Any Taco product or part not installed or operated in conformity with Taco instructions or which has been subject to misuse, misapplication, the addition of petroleum-based fluids or certain chemical additives to the sys-

tems, or other abuse, will not be covered by this warranty.

If in doubt as to whether a particular substance is suitable for use with a Taco product or part, or for any application restrictions, consult the applicable Taco instruction sheets or contact Taco at (401-942-8000).

Taco reserves the right to provide replacement products and parts which are substantially similar in design and functionally equivalent to the defective product or part. Taco reserves the right to make changes in details of design, construction, or arrangement of materials of its products without notification.

TACO OFFERS THIS WARRANTY IN LIEU OF ALL OTHER EXPRESS WARRANTIES. ANY WARRANTY IMPLIED BY LAW INCLUDING WARRANTIES OF MERCHANTABILITY OR FITNESS IS IN EFFECT ONLY FOR THE DURATION OF THE EXPRESS WAR-

RANTY SET FORTH IN THE FIRST PARAGRAPH ABOVE.

THE ABOVE WARRANTIES ARE IN LIEU OF ALL OTHER WARRANTIES, EXPRESS OR STATUTORY, OR ANY OTHER WARRANTY OBLIGATION ON THE PART OF TACO.

TACO WILL NOT BE LIABLE FOR ANY SPECIAL, INCIDENTAL, INDIRECT OR CONSEQUENTIAL DAMAGES RESULTING FROM THE USE OF ITS PRODUCTS OR ANY INCIDENTAL COSTS OF REMOVING OR REPLACING DEFECTIVE PRODUCTS.

This warranty gives the purchaser specific rights, and the purchaser may have other rights which vary from state to state. Some states do not allow limitations on how long an implied warranty lasts or on the exclusion of incidental or consequential damages, so these limitations or exclusions may not apply to you.

Taco Comfort Solutions® A Taco Family Company

Taco, Inc., 1160 Cranston Street, Cranston, RI 02920 | Tel: (401) 942-8000 | FAX: (401) 942-2360

Taco (Canada), Ltd., 8450 Lawson Road, Suite #3, Milton, Ontario L9T 0J8 | Tel: (905) 564-9422 | FAX: (905) 564-9436

Visit our web site: www.TacoComfort.com | ©2021 Taco, Inc.



SUPERSEDES: February 23, 2021

EFFECTIVE: August 16, 2021

Plant ID No. 001-5023

DESCRIPTION:

The 007^e stainless steel is a variable speed, high-efficiency wet rotor circulator with ECM permanent magnet technology. Its ECM performance is equivalent to the legendary 007 and is ideal for open loop potable hot water systems with up to 500 feet of recirculation piping. It reduces power consumption by up to 85% compared to equivalent AC permanent split capacitor circulators.

APPLICATION:

- Maximum operating pressure: 150 psi (10 bar)
- Maximum water temperature: 230°F (110°C)
- Electrical specifications:
 - Voltage: 110-120V, 50/60 Hz, single phase
 - Maximum operating power: 44W
 - Maximum amp rating: 0.54
- Equipped with a stainless steel casing with 4-bolt universal flanges or 1" union connections
- Use on open loop potable hot water recirculation systems with up to 500 feet of pipe or closed loop hydronic heating systems
- Not suitable for chilled water systems
- Taco circulator pumps are for indoor use only
 - employer uniquement a l'interieur
- Acceptable for use with water or maximum of 50% water/glycol solution

FEATURES:

- ECM performance equivalent to Taco's legendary 007 circulator
- Use with Taco SmartPlug Instant Hot Water Control® for hot water when you need it
- Multi-color LED showing operating mode and error code diagnostics
- 4-bolt universal flange or 1" Union connection, stainless steel casing
 - Nut-capture feature on flanges for easier fit-up
 - Optional 1/2" & 3/4" union fitting sets available - sweat, NPT or press (sold separately)
- Dual electrical knockouts and 6" stranded wire leads for easy wiring
- Double insulated - no ground-wire required
- Integral Flow Check (IFC®) included - Field installed
- Whisper quiet operation
- **SureStart®** - automatic unblocking and air purging mode
- Green Mode active system monitoring and power optimization

Figure 1:

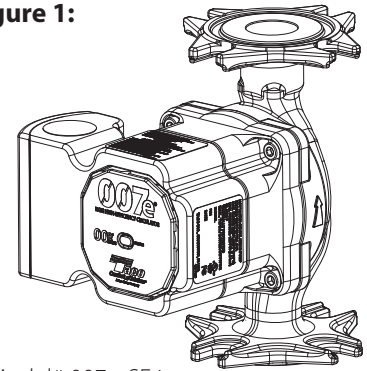

Model# 007e-SF4

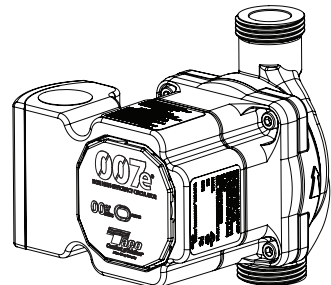

Model# 007e-SU



Certified to
NSF/ANSI 61 & 372



INSTALLATION:



WARNING: Follow all local plumbing and electrical codes when installing this product.

AVERTISSEMENT: Respectez tous les codes de plomberie et d'électricité locaux lors de l'installation de ce produit.



CAUTION: To ensure all plumbing system components are protected from the damaging effects of water hammer, be sure an approved water hammer arrestor is installed in the system per locally recognized National plumbing codes.

ATTENTION: Respectez tous les codes de plomberie et d'électricité locaux lors de l'installation de ce produit.



WARNING: Do not use in swimming pool or spa areas. Pump has not been investigated for these applications.

AVERTISSEMENT: Ne pas utiliser dans une piscine ou un spa. La pompe n'a pas été étudiée pour ces applications.



CAUTION: The addition of petroleum based fluids or certain chemical additives to systems using TACO equipment voids the warranty. Consult factory for fluid compatibility.

ATTENTION: L'ajout de liquides à base de pétrole ou de certains additifs chimiques à des systèmes utilisant un équipement TACO annule la garantie. Consultez le fabricant pour connaître la compatibilité de liquides.



CAUTION: Installations at elevations over 5000 feet must have higher fill pressure of 20 psi minimum to prevent pump cavitation and flashing. Premature failure may result. Adjust expansion tank pressure to equal fill pressure. A larger size expansion tank may be required.

ATTENTION: Des installations à des altitudes de plus de 1600 mètres doivent présenter une pression de remplissage plus élevée de 20psi au minimum afin d'éviter toute cavitation ou flashing de la pompe. Une défaillance prématurée peut en résulter. Réglez la pression du réservoir d'expansion de façon qu'elle soit égale à la pression de remplissage. Un réservoir d'expansion d'une taille supérieure peut être nécessaire.

**Figure 2:
Typical Installation for Hot Water Recirculation Systems**

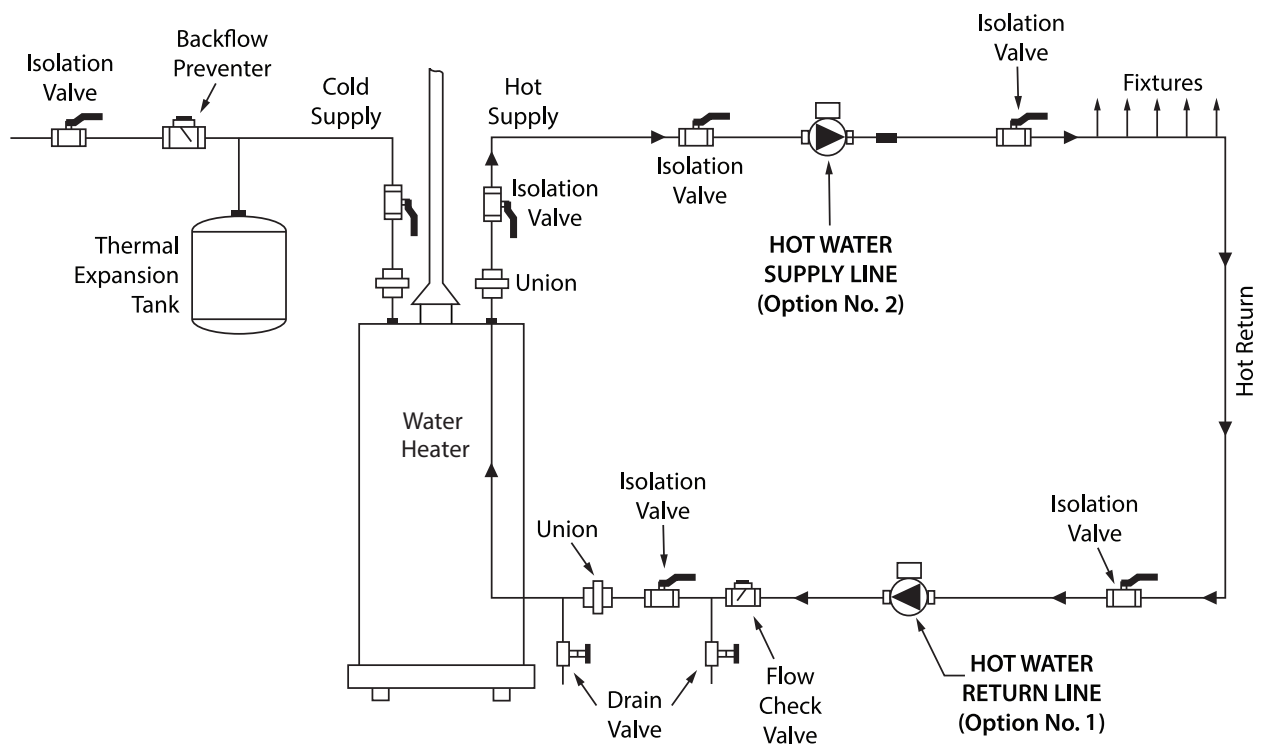

Recommended Purging Steps:

1. Open fixture at highest point in system
2. Open all isolation valves
3. Once system is filled, close the fixture at the highest point in the system
4. Close isolation valve on pump discharge (Option No. 1 location)
5. Open drain valve on pump discharge until all remaining air has been purged
6. Close drain valve
7. Operate pump until all remaining air is purged from bearing chamber

Figure 3:
Typical Installation for Zoned Hydronic Heating Systems

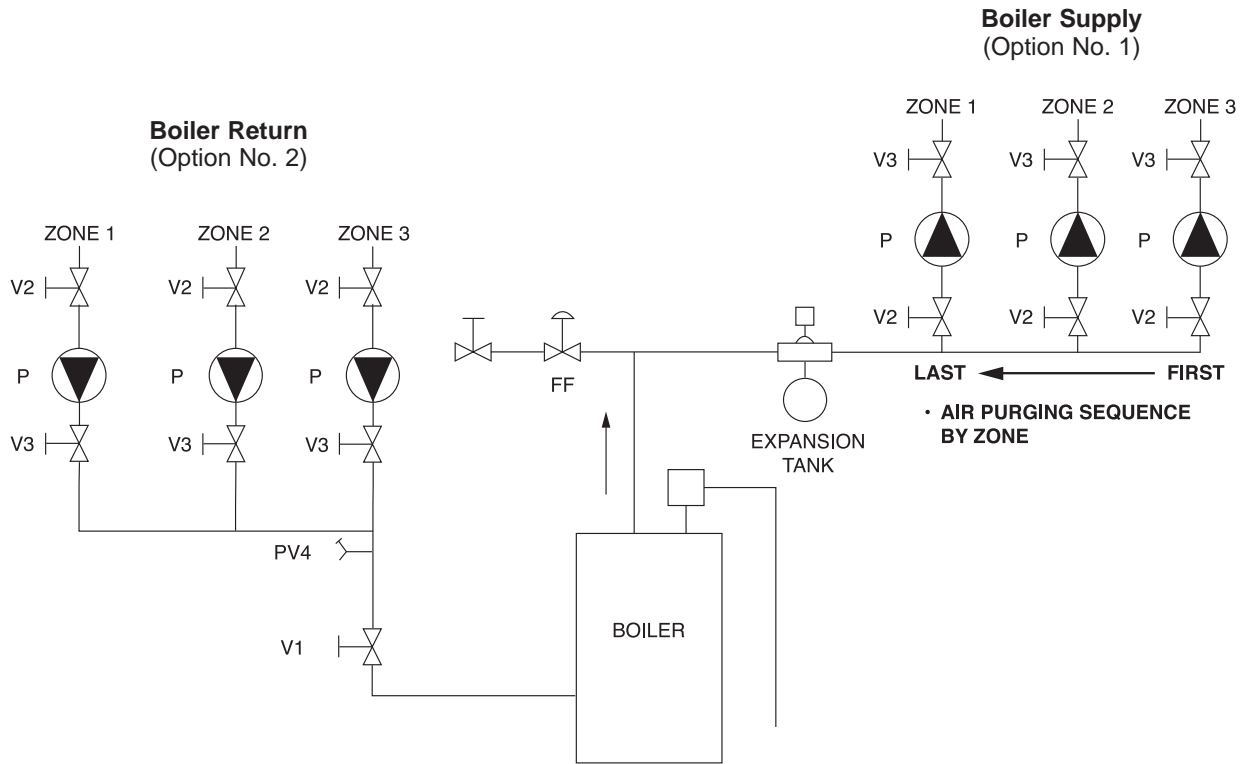

Key:

V1, V2, V3 = Shut-off Isolation Valve
 P = Taco circulator with IFC installed
 FF = Fast Fill Boiler Feed Valve
 PV4 = Purge Valve

Recommended Purging Steps:

1. Close V1, PV4, V2
2. Open V3
3. Open FF valve
4. Open V2, PV4, to purge last zone First (Zone 3)
5. Close FF Valve
6. Close V2, PV4
7. Repeat steps 1 to 6 for each additional zone, purge zone 1 last
8. Open V1 when all zones are purged
9. Adjust system to desired operating fill pressure if required

- 1. Location:** The circulator can be installed on the supply or return side of the water heater or heat source. See Figures 2 & 3 on pages 3 and 4 for preferred locations.
- 2. Mounting Position:** Circulator must be mounted with the motor in the horizontal position. See diagrams below for acceptable motor mounting orientations.
- 3. Flange Model:** Fasten circulator to system piping. The circulator flanges incorporate a nut-grabber feature for easier installation.

CAUTION: Do not use flat rubber gaskets. Only use O-ring gaskets provided or leaks may result. Warranty will be voided.

- 4. Union Model:** Install the union tailpiece fitting set (sold separately) best suited for your system piping. (See Union Fitting Options chart on the back cover). Install circulator by attaching pump casing to each union tailpiece fitting. Tighten union nut onto circulator threading (being careful not to overtighten) to complete the installation.

CAUTION: Only use union gaskets provided with union fitting sets or leaks may result. Warranty will be voided.

ACCEPTABLE MOTOR MOUNTING POSITIONS AND EASY CASING ROTATION

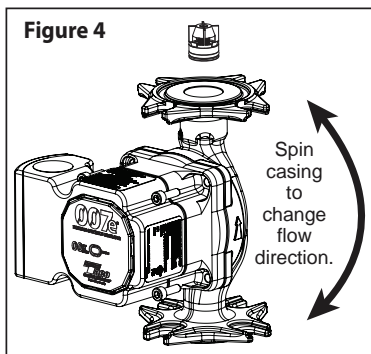

Always install with motor in horizontal orientation. Position electrical junction box at 9 o'clock for best viewing orientation. Pump casing may be rotated to change flow direction. Locate the arrow on the casing body to determine flow direction.

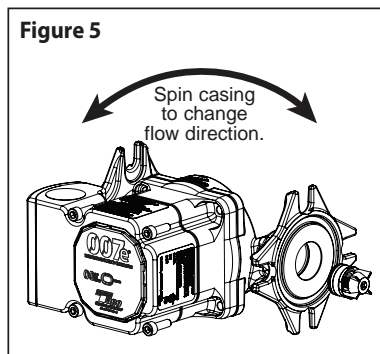

To rotate the pump casing, remove the 4 motor screws. **When rotating pump casing position, DO NOT detach motor housing from the casing.** Damage to the casing O-ring and leakage may result. Simply spin casing to the proper flow direction desired as shown in Figure 4 and Figure 5. Reattach the 4 screws (1/8" allens wrench required). Be sure motor is positioned correctly and is seated evenly to prevent leakage or damage to O-ring. Tighten motor screws evenly to **25-38** in-lbs torque.

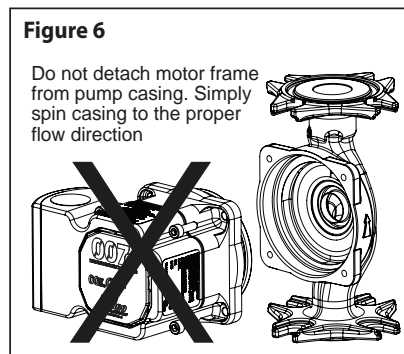

Integral Flow Check (IFC[®]) option — An IFC[®] is included in carton. If required, press IFC into the machined discharge port with plunger and O-ring facing in, until it snaps into place. Before installing, press IFC plunger to be sure it moves freely. See figures 4 & 5 above

- 5. Filling the system:** The system must be filled before operating the circulator. The bearings are water lubricated and should not be allowed to operate dry. It is always good practice to flush a new system of foreign matter before starting the circulator. See page 3 for recommended air purging steps.

CAUTION: To reduce the possibility of noise transmission, be sure to add vibration dampeners to piping when mounting circulator to wall or floor joists.

ATTENTION: Pour réduire la possibilité de transmission de bruit, veuillez à ajouter des amortisseurs de vibration à la tuyauterie lors du montage du circulateur sur des chevêtres de mur ou de plancher.

WARNING: Risk of electric shock. To reduce the risk of electric shock, be certain that it is connected only to a properly grounded, grounding-type receptacle. Follow all local electrical and plumbing codes.

AVERTISSEMENT: Risque de choc électrique. Pour réduire le risque de choc électrique, veuillez à ce qu'elle soit raccordée uniquement à un réceptacle de type mise à la terre proprement mis à la terre. Respectez tous les codes de plomberie et électriques locaux.



WARNING: Use supply wires suitable for 90°C.
AVERTISSEMENT: Employer des fils d'alimentation adéquats pour 90°C.



WARNING: Disconnect power when servicing.
AVERTISSEMENT: Couper l'alimentation lors de l'entretien.



CAUTION: Use flexible conduit only. Not for use with rigid conduit.
AVERTISSEMENT: N'utiliser que du conduit flexible ; n'est pas fait pour du conduit rigide.



WARNING: SERVICING OF DOUBLE-INSULATED APPLIANCES. A double-insulated appliance is marked with one or more of the following:

The words "DOUBLE INSULATION" or "DOUBLE INSULATED" or the double insulation symbol (square within a square). In a double-insulated appliance, two systems of insulation are provided instead of grounding. No grounding means is provided on a double-insulated appliance, nor should a means for grounding be added.

Servicing a double-insulated appliance requires extreme care and knowledge of the system, and should be done by qualified service personnel. Replacement parts for a double-insulated appliance must be identical to the parts they replace.

5. Wiring the circulator: Disconnect the AC power supply. Remove the terminal box cover. Attach a wiring connector into the knockout hole. Use a flexible conduit only. Connect Line/Hot power to the black lead, neutral to the white lead. See wiring diagram to the right. Replace the terminal box cover.

Note: If pigtail leads provided are not used, be sure to trim field wire to a strip length of .25" (+/- .025") to prevent exposed wire causing a short at the terminal plug. Connect line and neutral to green terminal plug as shown in the Wiring Diagram. Depress the spring tab with a small screwdriver to insert wire into the plug. Release tabs to complete connection. The 007e is a double insulated circulator. No grounding wire is necessary.

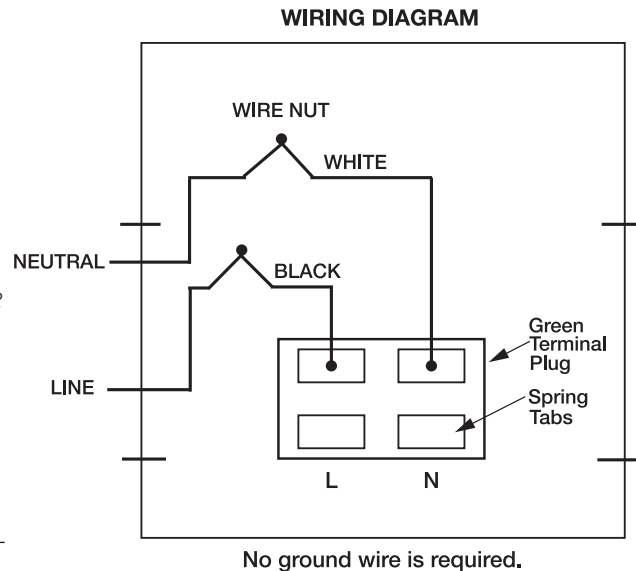

6. Start the circulator: When purging the system, it is recommended to run the circulator long enough to remove all remaining air from the bearing chamber. This is especially important when installing the circulator in the off-season. An orange LED will illuminate when the 007e is powered on.

7. Green Mode: Responsive technology actively monitors system conditions and automatically adjusts to optimize power consumption. In this mode the LED changes to green. Consult with the factory for directions to access Green Mode.



CAUTION: Never run the circulator dry or permanent damage may result.
ATTENTION: Ne laissez jamais le circulateur tourner à sec, des dommages permanents peuvent en résulter.



CAUTION: Do not attempt to remove LED panel from circulator. Serious damage to circulator electronics may result.
ATTENTION: N'essayez pas de retirer le panneau de LED du circulateur. Des dommages sérieux à l'électronique du circulateur peuvent en résulter.

007e Performance Curves

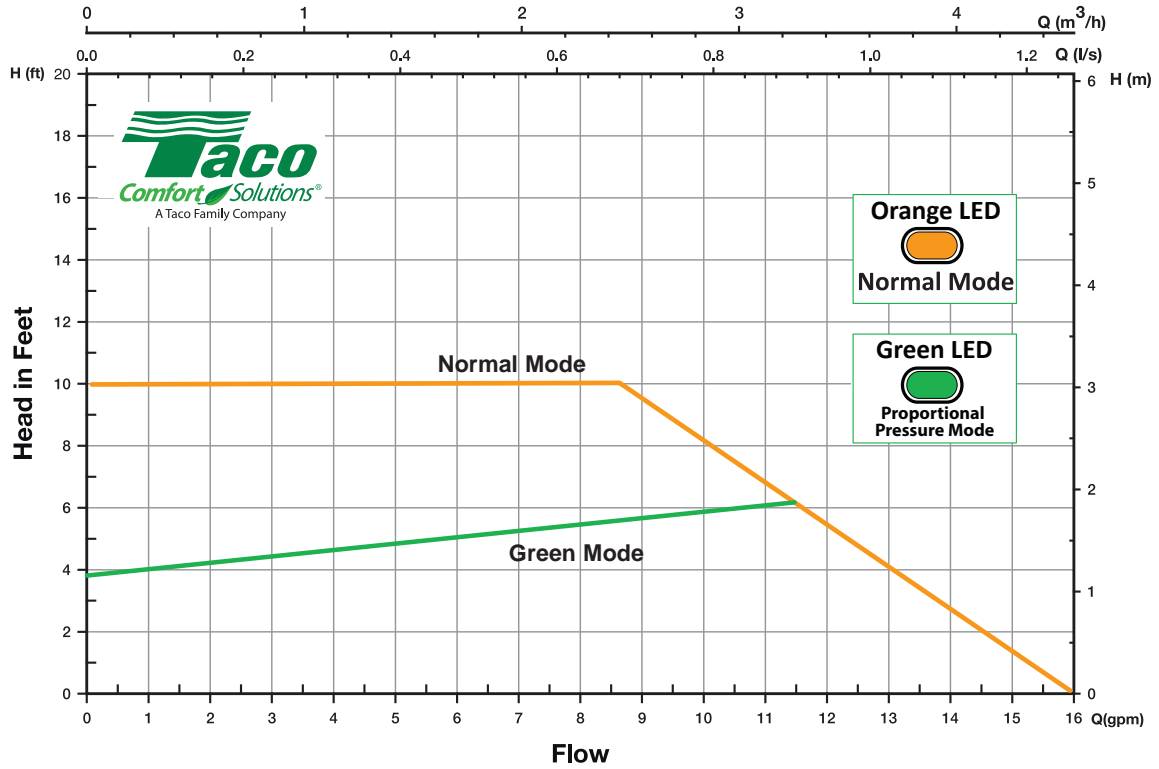

8. Troubleshooting the error codes: Listed below are potential diagnostic error codes which will appear on the LED display in case of a malfunction.

FAULTS	CONTROL PANEL	CAUSES	REMEDIES
The circulator is noisy	LED on	Suction pressure is insufficient — cavitation	Increase the system suction pressure within the permissible range.
	LED on	Presence of foreign bodies in the impeller	Disassemble the motor and clean the impeller.
Loud noises of water circulation	Flashing white LED	Air in the system. Pump may be air-bound	Vent the system. Repeat fill and purge steps.
Circulator is not running although the electrical power supply is switched on	LED off	Lack of power supply	Verify voltage value of the electric plant. Verify the connection of the motor.
		Circuit breaker might be tripped	Check circuit breaker at panel and reset if necessary.
		The circulator is defective	Replace the pump.
		Overheating	Let the pump cool down for some minutes. Then try to restart it. Verify that the water and ambient temperature are within the indicated temperature ranges.
	LED red	The rotor is blocked	Disassemble the motor and clean the impeller. See unlocking procedure below.
		Insufficient supply voltage	Verify that the power supply matches the data on the name plate.
Building does not get warm.	LED on	System may be air-bound	Vent system. Repeat fill and purge steps.

9. Unlocking Procedure: A red LED indicates the circulator is locked or sticking. Disconnect and connect power supply to start the automatic release process. The circulator makes 100 attempts to restart (process lasts approximately 15 minutes). Every restart is signaled by a short white flash of LED light. If the locking is not removed through the automatic release process after 100 attempts to restart the circulator, it goes into standby and the LED remains red. In this case follow the manual procedure described in the next steps: during any attempt, the red LED light keeps blinking; after that the circulator tries again to start. If the locking is not removed through the automatic release process (the warning light returns to be red), perform the manual steps described below.

1. Disconnect power supply - the warning light switches off
2. Close both isolating valves and allow cooling. If there are no shut-off devices, drain the system so that the fluid level is beneath that of the circulator
3. Loosen 4 motor bolts. Remove motor from casing. Carefully pull the rotor/impeller from the motor
4. Remove impurities and deposits from the impeller and casing
5. Reinsert the rotor/impeller into the motor
6. Connect power supply. Check for impeller rotation
7. If the circulator still doesn't run it will need to be replaced

REPLACEMENT PARTS	
Part#	Description
198-213 RP	Casing O-ring
198-214 RP	Wiring plug connector (green)
198-215 RP	Terminal box cover (black)
198-217 RP	Terminal box cover screws (5 per bag)
0010-025 RP	Integral Flow Check (IFC®)
007-007 RP	Flange Gasket Kit

Lead-Free Shut-Off <i>freedom</i> FLANGE (SOLD SEPARATELY)	
Part#	Description
SFL-050T	1/2" NPT
SFL-050S	1/2" Sweat
SFL-075T	3/4" NPT
SFL-075S	3/4" Sweat
SFL-100T	1" NPT
SFL-100S	1" Sweat
SFL-125T	1-1/4" NPT
SFL-125S	1-1/4" Sweat
SFL-150T	1-1/2" NPT
SFL-150S	1-1/2" Sweat

UNION FITTING SETS (SOLD SEPARATELY)	
Part#	Description
UFS-050S	1/2" Sweat tailpiece set
UFS-050T	1/2" NPT tailpiece set
UFS-050P	1/2" Press tailpiece set
UFS-075S	3/4" Sweat tailpiece set
UFS-075T	3/4" NPT tailpiece set
UFS-075P	3/4" Press tailpiece set

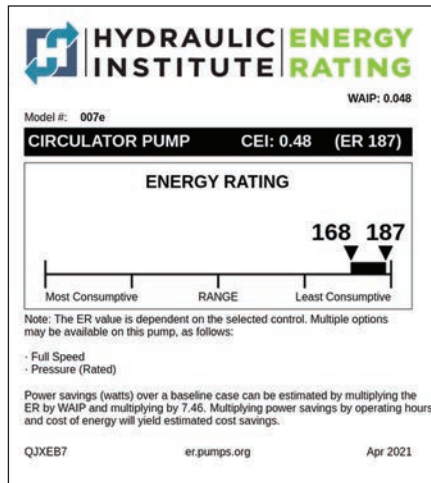

LIMITED WARRANTY STATEMENT

Taco, Inc. will repair or replace without charge (at the company's option) any Taco product which is proven defective under normal use within three (3) years from the date of manufacture.

In order to obtain service under this warranty, it is the responsibility of the purchaser to promptly notify the local Taco stocking distributor or Taco in writing and promptly deliver the subject product or part, delivery prepaid, to the stocking distributor. For assistance on warranty returns, the purchaser may either contact the local Taco stocking distributor or Taco. If the subject product or part contains no defect as covered in this warranty, the purchaser will be billed for parts and labor charges in effect at time of factory examination and repair.

Any Taco product or part not installed or operated in conformity with Taco instructions or which has been subject to misuse, misapplication, the addition of petroleum-based fluids or certain chemical additives to the systems, or other abuse, will not be covered by this warranty. If in doubt as to whether a particular

substance is suitable for use with a Taco product or part, or for any application restrictions, consult the applicable Taco instruction sheets or contact Taco at (401-942-8000).

Taco reserves the right to provide replacement products and parts which are substantially similar in design and functionally equivalent to the defective product or part. Taco reserves the right to make changes in details of design, construction, or arrangement of materials of its products without notification.

TACO OFFERS THIS WARRANTY IN LIEU OF ALL OTHER EXPRESS WARRANTIES. ANY WARRANTY IMPLIED BY LAW INCLUDING WARRANTIES OF MERCHANTABILITY OR FITNESS IS IN EFFECT ONLY FOR THE DURATION OF THE EXPRESS WARRANTY SET FORTH IN THE FIRST PARAGRAPH ABOVE.

THE ABOVE WARRANTIES ARE IN LIEU OF ALL OTHER WARRANTIES, EXPRESS OR STATUTORY, OR ANY OTHER WARRANTY OBLIGATION ON THE PART OF TACO.

TACO WILL NOT BE LIABLE FOR ANY SPECIAL INCIDENTAL, INDIRECT OR CONSEQUENTIAL DAMAGES RESULTING FROM THE USE OF ITS PRODUCTS OR ANY INCIDENTAL COSTS OF REMOVING OR REPLACING DEFECTIVE PRODUCTS.

This warranty gives the purchaser specific rights, and the purchaser may have other rights which vary from state to state. Some states do not allow limitations on how long an implied warranty lasts or on the exclusion of incidental or consequential damages, so these limitations or exclusions may not apply to you.

Taco Comfort Solutions® A Taco Family Company

Taco, Inc., 1160 Cranston Street, Cranston, RI 02920 | Tel: (401) 942-8000 | FAX: (401) 942-2360

Taco (Canada), Ltd., 8450 Lawson Road, Suite #3, Milton, Ontario L9T 0J8 | Tel: (905) 564-9422 | FAX: (905) 564-9436

Visit our web site: www.TacoComfort.com | ©2021 Taco, Inc.

